

DARING COMPANY

5 GALLON PAIL MELTER

1225 VER 1-3

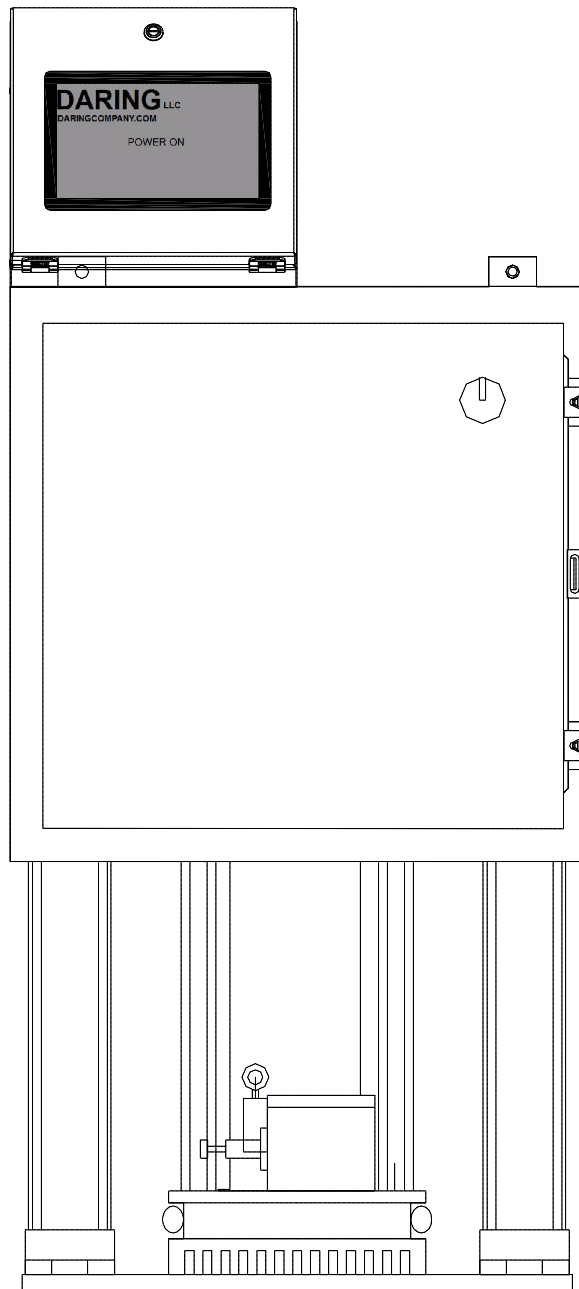

DARING LLC.
180 Engelwood Drive
Suite B
Orion MI 48359
Fax (248) 340-0753
Ph. (248) 340-0741

TABLE OF CONTENTS

1.0 Equipment overview	3
1.1 General location of controls	3
1.2 Temperature controller overview	5
1.3 System function overview	6
2.0 Temperature controller.....	7
2.1 Setting temperature.....	7
2.3 Turning channels on and off.....	8
3.0 Operation.....	9
3.1 First start up.....	9
3.2 Daily start up	9
3.3 Daily shut down.....	9
3.4 Drum change.....	10
3.4.1 Drum removal.....	10
3.4.2 Adding a new drum.....	11
4.0 Maintenance	15
4.1 Lubrication.....	15
4.2 Assembly drawing.....	16
4.3 Parts list.....	17

1.0 Equipment overview

1.1 General location of controls

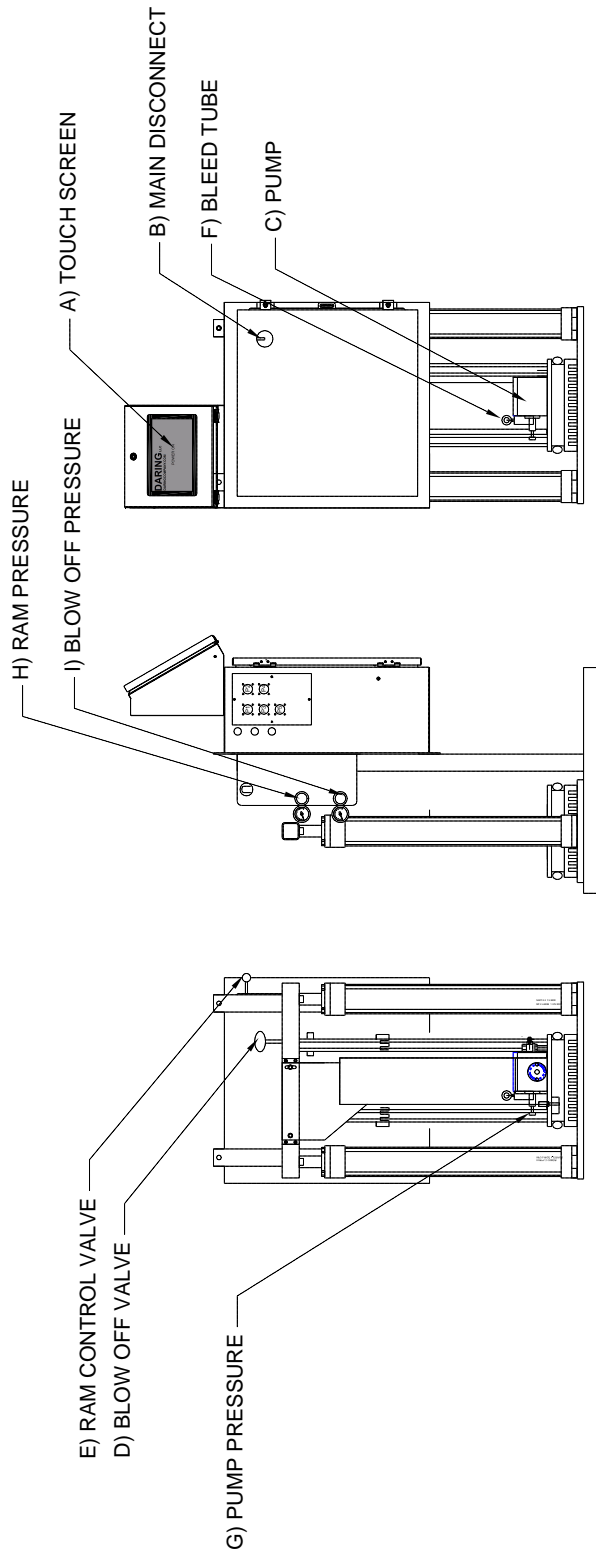

- A) Touch screen
Touch the screen to start.
- B) Main disconnect
Turns off power coming into the electrical box (should be lock out for electrical repair).
- C) Pump.
- D) Blow off valve
When this knob is pulled up it adds air pressure under the platen seal relieving the vacuum, and allowing the 5 gallon pail to be removed.
- E) Ram control valve.
Controls the up, down and, neutral ram position.
- F) Bleed tube
The bleed tube removes pockets of air during a pail change.
- H) Ram pressure.
Controls downward force on the pump rams do not exceed 60 psi.
- I) Blow off pressure
Controls the pressure used in relieving the vacuum under the platen seal allowing the 5 gallon pail to be removed (do not exceed 15 PSI)

1.2 Temperature controller overview

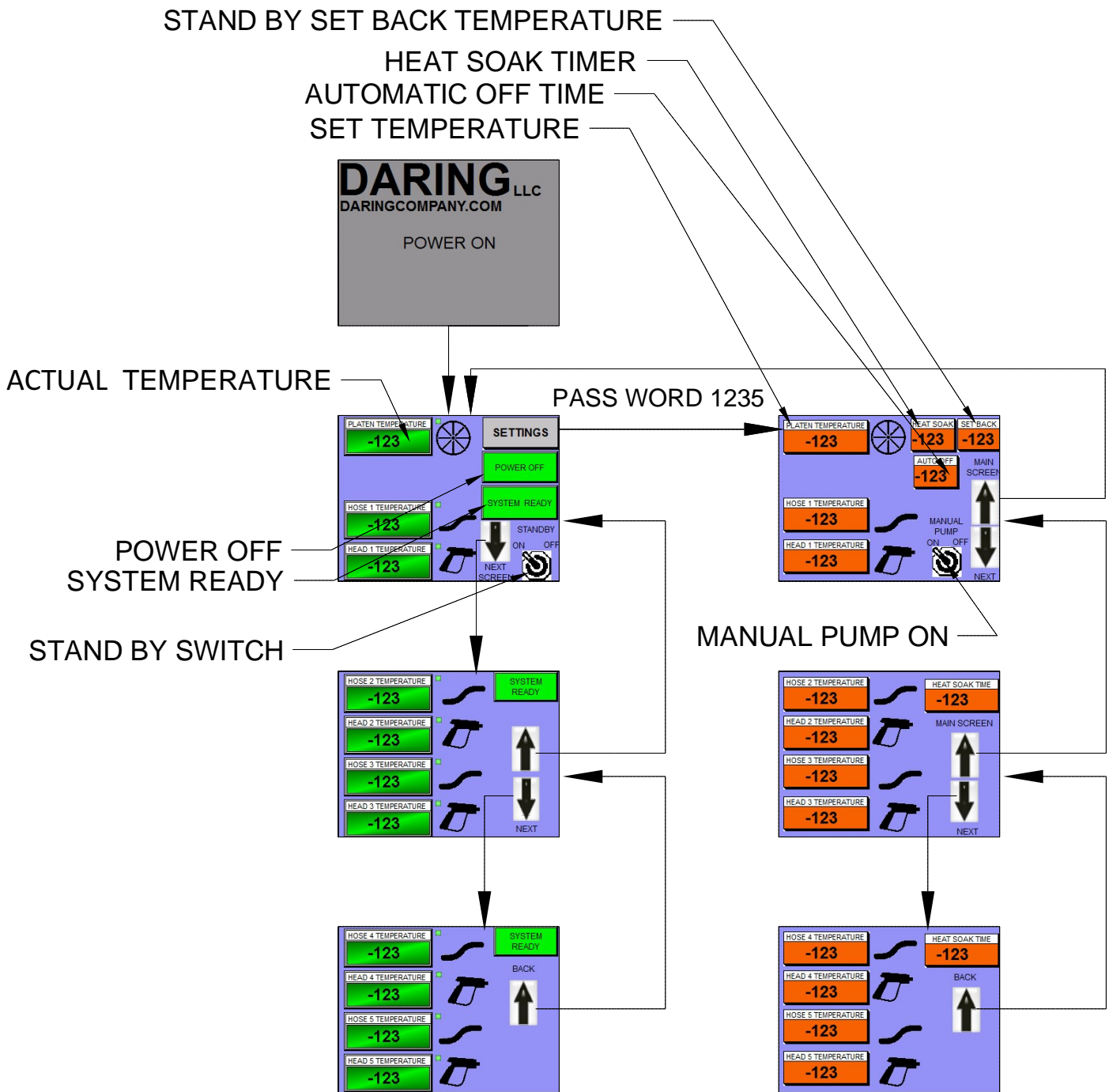

Note: above shows optional 5 hose system

1.3 System function overview

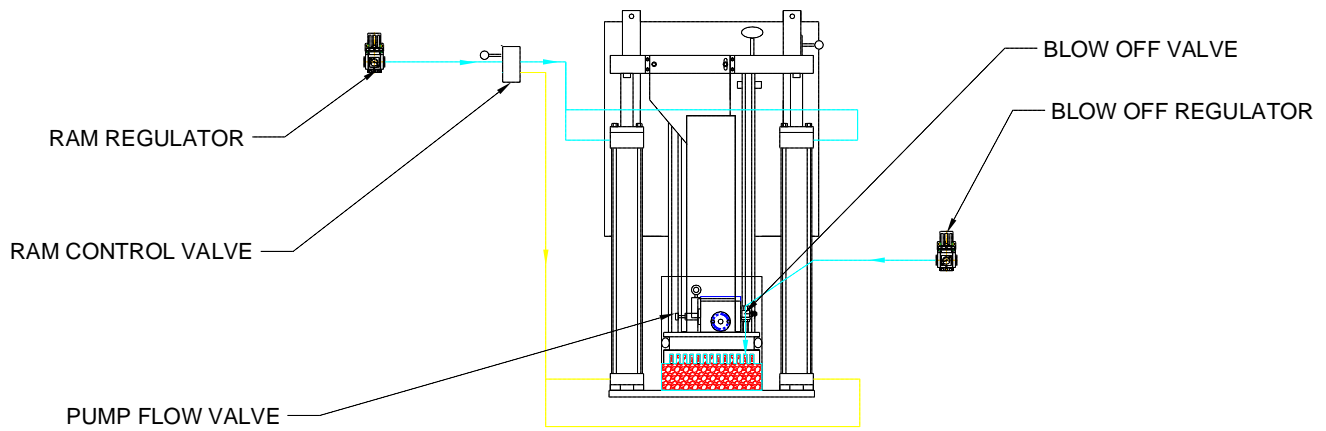

The platen is driven into the hot melt by pneumatic rams. The platen which is heated melts a thin layer of hot melt under it. A gear pump driven by an electric motor pressurizes the hot melt sending it through a heated hose to a heated dispense head.

2.0 Temperature controller

2.1 Setting temperature

Warning, When setting temperature follow adhesive manufacture recomendaytions.

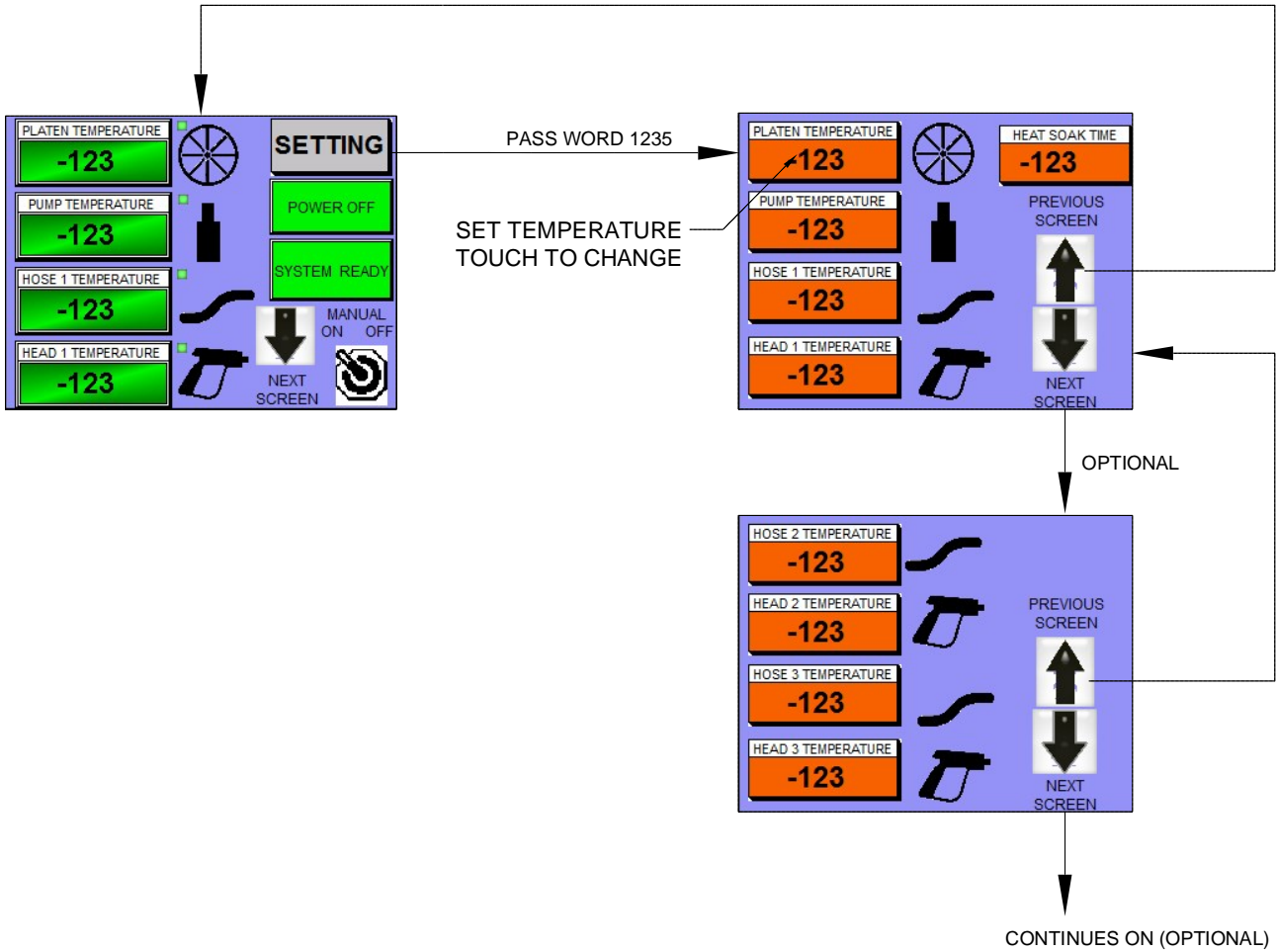

2.3 Turning channels on and off

Some systems do not use all of the channels. The channels are automatically turned off if the system power on screen is touched when the sensors are not present.

THESE CHANNELS ARE OFF

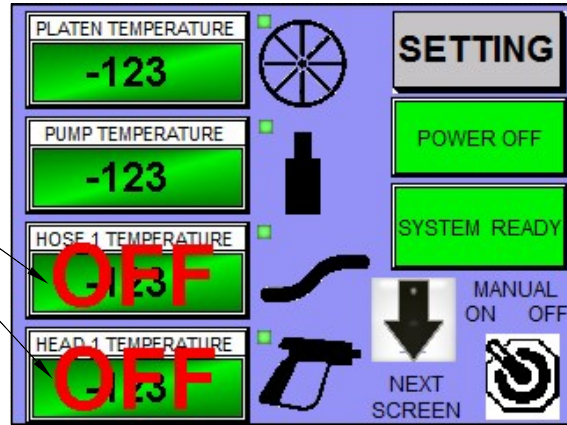

3.0 Operation

3.1 First start up

Step 1: Remove all packaging.

Step 2: Attach hoses and heads.

Step 3: Plug in hoses and heads

Step 4: Attach power to main disconnect.

Step 5: Turn on main disconnect.

Step 6: Touch main screen to power up.

Step 7: Allow system to come up to temperature.

Step 8: Wait 20 minutes for the heat soak.

Step 9: Load 5 gallon pail (See 3.4.2 adding a new pail)

Step 10: Slowly bring up pump pressure.

Step 11: Ready to run production.

3.2 Daily start up

Step 1: Turn on main disconnect. (If necessary)

Step 2: Touch main screen to power up

Step 3: Allow system to come up to temperature.

Step 4: Wait 20 minutes for the heat soak.

Step 5: Turn pump on.

Step 6: Ready to run production.

3.3 Daily shut down

Step 1: Turn off power on screen.

Step 2: Turn off all air.

3.4 Pail change
3.4.1 pail removal

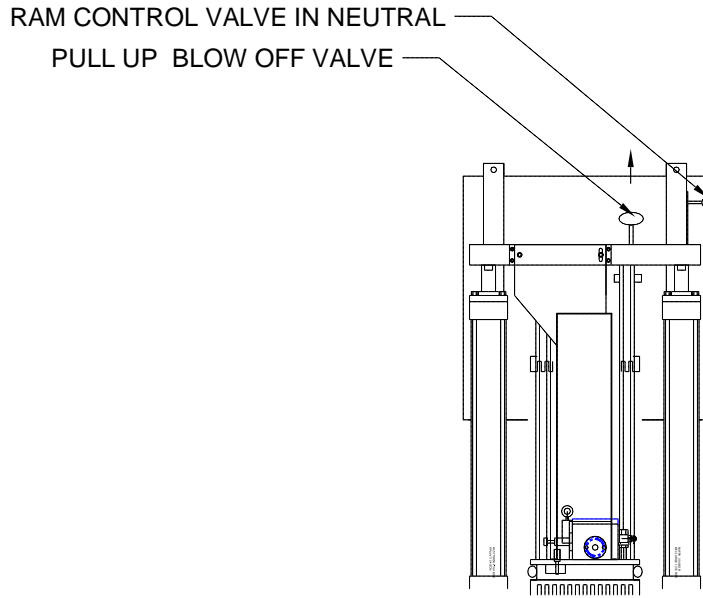

Warning: System must be at a high temperature. Must wear face shield, high temperature gloves, long sleeve shirt, and long pants. No exposed skin present during drum change. Keep body clear of pinch points.

- Step 1: Turn pump off
- Step 2: Place ram control in neutral position
- Step 3: Pull up on blow off knob.
- Step 4: Wait until platen seals clear 5 gallon pail.

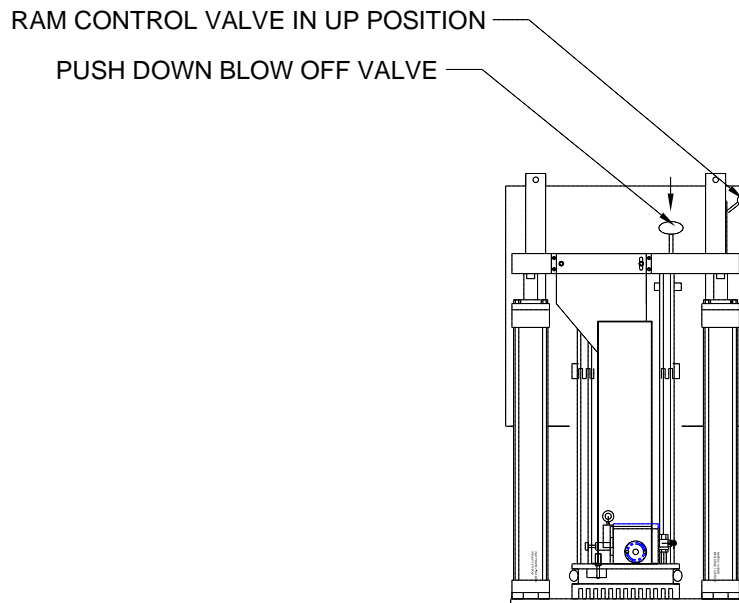

- Step 5: Put the ram control knob in the up position.
- Step 6: Turn off blow off valve by pressing it down.
- Step 7: Allow hot melt to drip into drum then remove the drum.

3.4.2 Adding a new pail

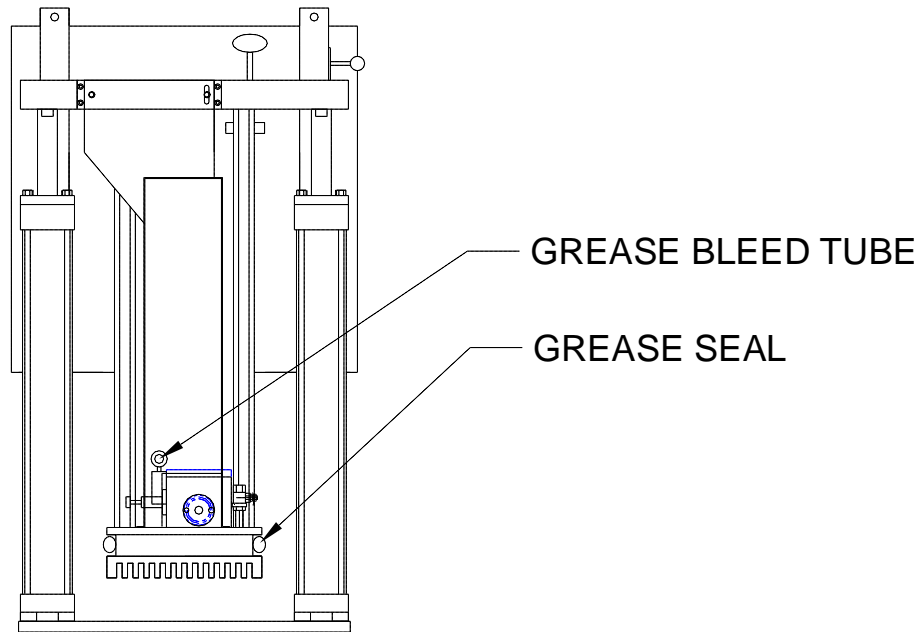

Warning: System must be at a high temperature. Must wear face shield, high temperature gloves, long sleeve shirt, and long pants. No exposed skin present during drum change. Keep body clear of pinch points.

Step 1: Turn pump off.

Step 2: Grease seals. (Uses high temperature non-sagging grease. Ask hot melt supplier for compatibility.)

Step 3: Align the 5 gallon pail under the platen.

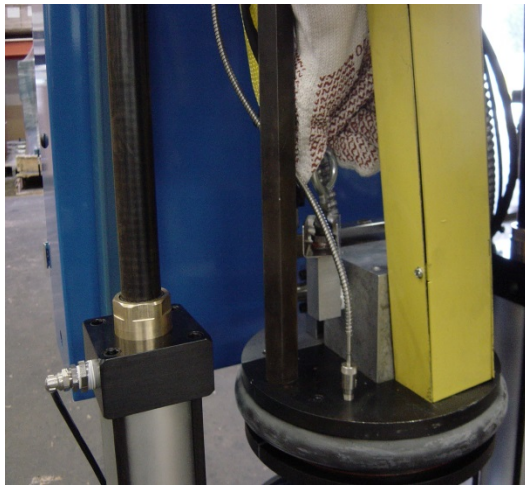

Step 4: Open bleed tube.

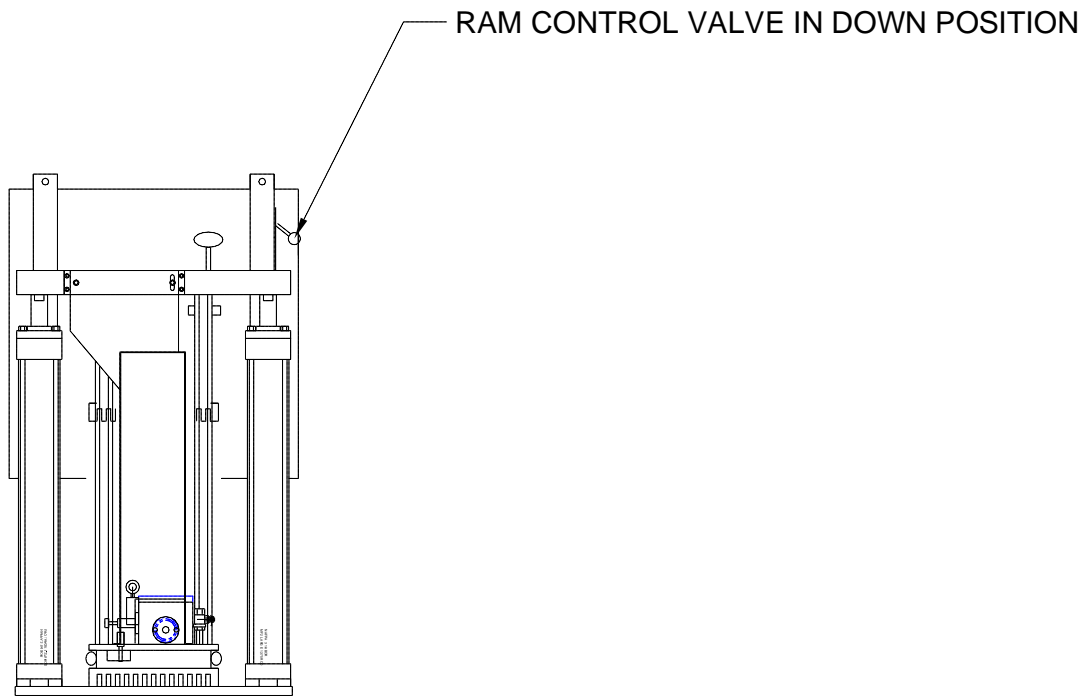

Step 5: Put the ram control in the down position.



Step 6: Allow air to escape and some hot melt to come out. (Place cup or rag to catch hot melt.)



Step 7: Replace bleed tube.

Step 8: Turn pump on.

4.0 Maintenance

4.2 Assembly drawing

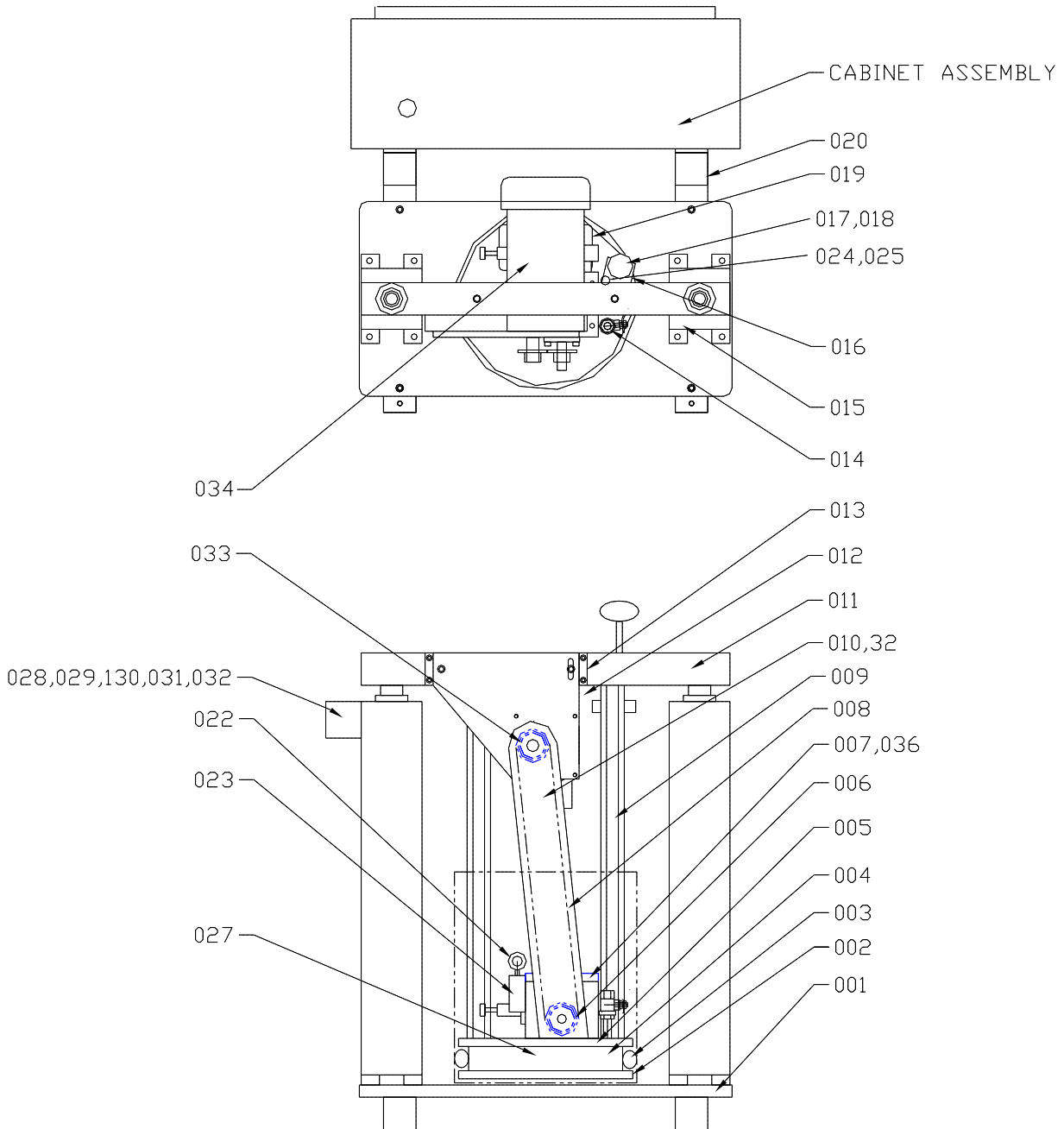

4.3 Parts list

Detail	Qty	Name	Part #
1	1	BASE	335-001
2	1	LOWER PLATEN	335-002
3	1	PLATEN SEAL	MK-4027
4	1	MIDDLE PLATEN	444-004
5	1	UPPER PLATEN	444-005R1
6	1	PUMP SPROCKET	40B10
7	1	PUMP	PA-40
9	2	SUPPORT	444-009R1
10	1	CHAIN GUARD	444-010R2
11	1	CROSS MEMBER	335-011
12	1	MOTOR PLATE	444-012R1
13	1	MOTOR SPACER	335-013
14	1	VALVE ASS'Y	
15	2	CYLINDER	TA-MF2-3.25x24-KK3-OS=1.375
16	1	SHAFT BRACKET	HI-058
17	1	METAL SHAFT	HI-059
18	1	KNOB	CL-852-0BK
19	1	COVER	335-019
20	2	PANEL SUPPORT	335-020
22	1	BLEED STEM	335-022
23	1	BLEED HOUSING	335-023
24	1	RTD	RBF1852P31
25	1	RTD HOLDER	705-0.88
27	4	HEATER 3/8 X 4 240VAC 1300 WATT	HDC00294
28	2	REGULATOR/ GAUGE	9690217
31	1	ELEVATOR VALVE	E612LM
32	1	CHAIN COVER	444-032R1
33	1	MOTOR SPROCKET	40B10
34	1	MOTOR	016-246-4029
35	1	PUMP O-RING	520-010
36	1	LIFT BAR	335-036
38	1	CHAIN	6261K102
41	0	ADJUST BLOCK	335-041
42	0	ADJUST RETAINER	335-042
43	1	GAUGE PLATE	335-043R1

